

PTFE-LINED BUTTERFLY VALVE T 211-A



Fully PTFE-lined wafer type valve for corrosive and aggressive media. The patented shaft seal design ensures reliability even with high-corrosive applications.

FEATURES

- PTFE-lined butterfly valve for chemically toxic and highly corrosive media
- Environmental protection via EBRO-Safety seal
- Splitted body design
- Isolation height according to plant prescription
- Can be installed in any desired position
- Maintenance-free
- Can be disassembled, material-specific recycling possible
- Material conform to FDA

GENERAL APPLICATIONS

- Chemically highly corrosive and toxic media
- Purification plants
- Pharmaceutical Industry
- Adhesives, Paper Industry, Fuel Transport
- Paint manufacture and processing
- Food Industry
- Transport of hazardous materials
- Wet chloric gas
- Conditioning of materials, e.g. galvanizing and pickling
- Processing of ore
- Fuel transport and storage

TECHNICAL DATA

Nominal diameter:	DN 50 – DN 300
Face-to-face:	EN 558 Series 20 (DIN 3202 T3 K1) ISO 5752 Series 20 API 609 Table 1 BS 5155, Tab. 6 Series 4 NF E 29-305.1
Flange accommodation:	DIN 2501 PN 10/16 ANSI B 16.5, Class 150 MSS SP44 Class 150 AWWA C 207 AS 2129 Table D and E BS 10 Table D and E JIS B 2211-5 K JIS B 2212-10K
Flange surface design:	DIN 2526 Design A-E, ANSI B 16.5 RF, FF
Top flange:	EN ISO 5211 NF E 29-402
Marking:	DIN EN 19
Tightness check:	DIN 3230 T3 BO (Leakage Rate 1) ISO 5208, Category 3 API 598 Table 5 and ANSI B 16-104, Class VI
Temperature range:	-40 °C to +200 °C (depending on operation pressure)
Operating pressure:	max. 10 bar, (16 bar for spec. version)
Differential pressure:	max. Δp 10 bar, (16 bar for spec. version)
Vacuum:	up to 1 mbar absolute (with silicon elastomer inserts) from -10 °C to +160 °C

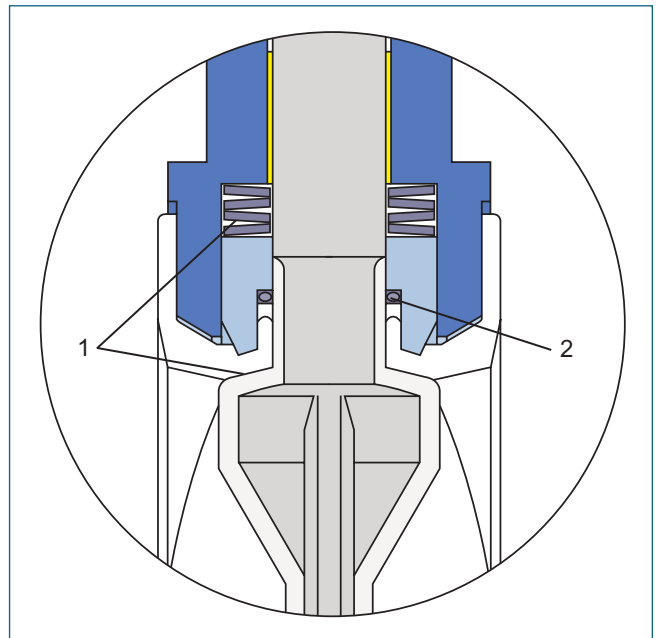

Safety seal at both shaft ends in accordance with the EBRO Twin Seal principle:

- 1 Primary sealing by means of a Belleville spring washer, transmitting prestress on the spherical segment area.
- 2 Secondary sealing of the shaft by means of PTFE-Chevron and O-Ring.

PTFE-LINED BUTTERFLY VALVE T 211-A

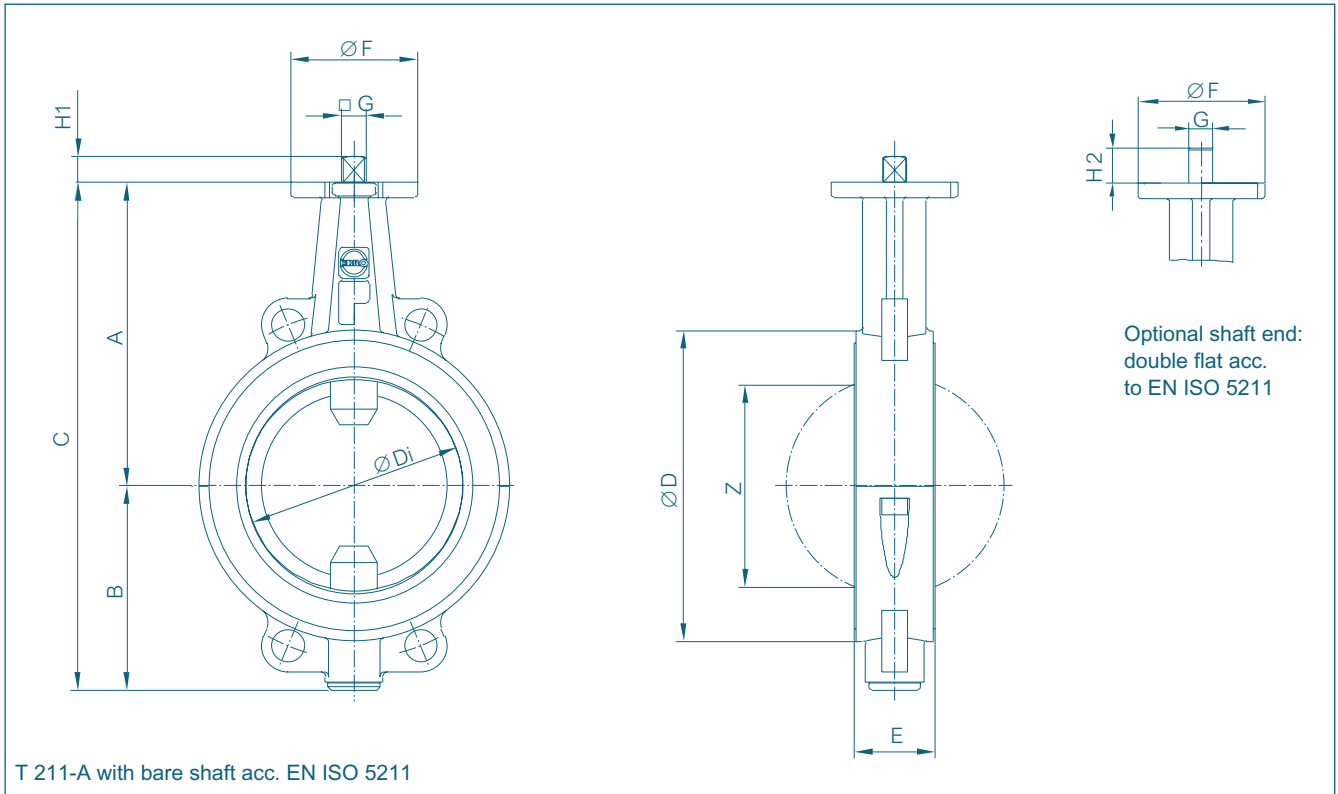

DN [mm]	Size [in]	Dimensions [mm]											Weight [kg]	
		A	B	C	D	Di	E	F	Flange	G	H1	H2		Z
50	2	135	80	215	112	60,8	43	54	F04	11	12	19	41	2,8
65	2½	150	82	232	120	60,8	46	54	F04	11	12	19	41	3,4
80	3	157	108	265	138	79,5	46	65	F05	14	16	25	66	4,5
100	4	180	118	298	160	99,0	52	65	F05	14	16	25	85	5,9
125	5	195	130	325	190	124,5	56	90	F07	17	19	25	112	8,1
150	6	210	142	352	215	150,5	56	90	F07	17	19	30	141	9,5
200	8	240	169	409	269	195,5	60	90	F07	17	19	30	187	15
250	10	275	217	492	324	247,5	68	125	F10	22	24	39	239	24
300	12	300	240	540	374	292,5	78	125	F10	22	24	39	283	34

Subject to change without notice.

ACTUATORS T 211-A

HAND LEVER

DN [mm]	Size [in]	Hand Lever	F	H	L	Weight [kg]
50-65	2-2½	Size II	54	80	195	0,15
80-100	3-4	Size III	65	100	276	0,5
125	5	Size III	90	100	276	0,5

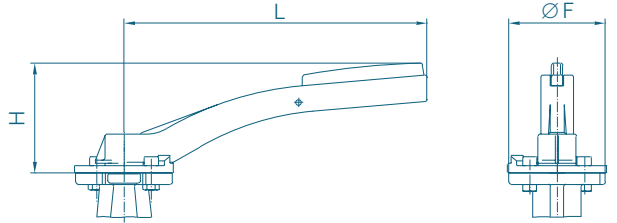

WORM GEAR

DN [mm]	Size [in]	Gear	H	J	K	L	Weight [kg]
50-100	2-4	Size II	89	39	125	159	1,4
125-150	5-6	Size III	129	47	200	202	2,3
200-250	8-10	Size IV	129	60	200	252	2,8
300	12	Size V	158	76	250	280	6,3

The dimensioning of actuators refers to an operating pressure of 10 bar.

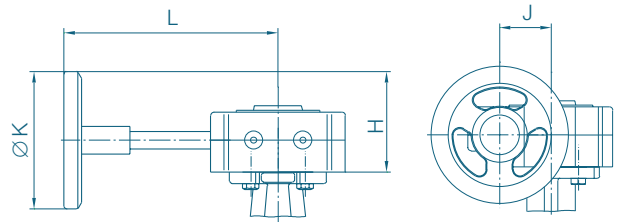

ELECTRIC ACTUATOR

DN [mm]	Size [in]	Actuator	H	J	K	L	M	Weight [kg]
50-80	2-3	E 65	233	172	80	139	119	7,0
100-250	4-10	E 110	251	245	125	139	134	14,0
300	12	E 160	239	279	198	139	157	25,0

The dimensioning of actuators refers to an operating pressure of 10 bar.

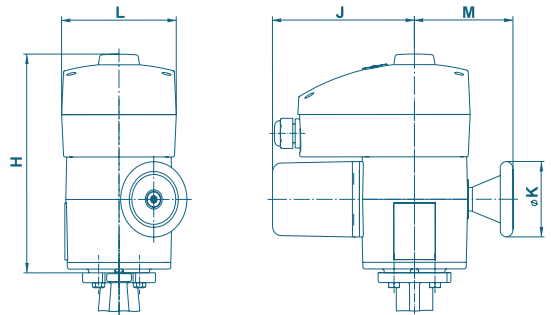

Subject to change without notice.

ACTUATORS T 211-A

PNEUMATIC DOUBLE ACTING

DN [mm]	Size [in]	Actuator Type	H	J	K	L	Weight [kg]
50-80	2-3	EB 5	108	88	55	174	1,7
100-125	4-5	EB 6	123	103	62	208	2,6
150-200	6-8	EB 8	136	115	68	250	4,3
250-300	10-12	EB 10	155	135	79	312	6,8

The dimensioning of actuators refers to an operating pressure of 10 bar and a control air pressure of 6 bar.

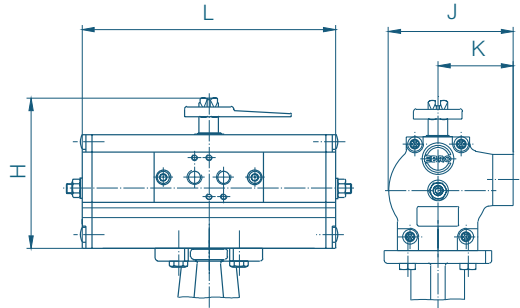

PNEUMATIC SPRING RETURN

DN [mm]	Size [in]	EBF Actuator	H	J	K	L	Weight [kg]
50-80	2-3	EB 6	123	103	62	326	5,0
100	4	EB 8	136	115	68	389	7,7
125-200	5-8	EB 10	155	135	79	526	14,3
250	10	EB 12	182	159	94	658	25,4
300	12	EB 265	232	152	76	634	27,0

The dimensioning of actuators refers to an operating pressure of 10 bar and a control air pressure of 6 bar.

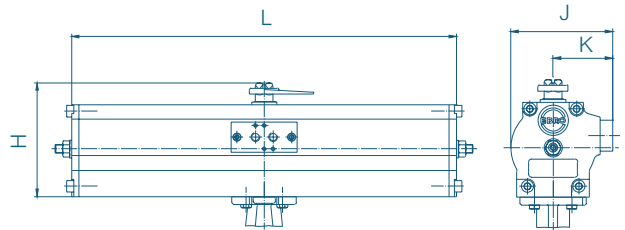

SWITCHBOX SERIES MSK/NSK

MSK: Switchbox with integrated micro limit switches.

NSK: Switchbox with integrated proximity switches.

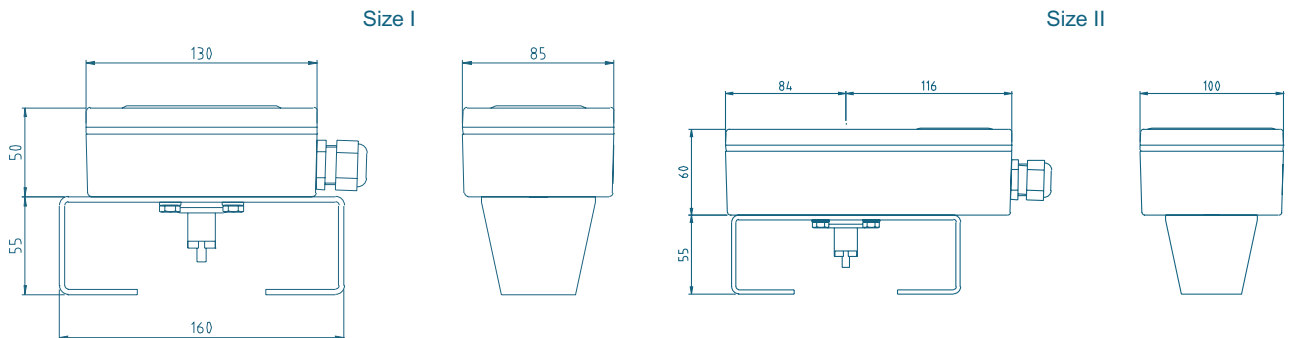

Subject to change without notice.

PTFE-LINED BUTTERFLY VALVE T 211-A

MATERIAL SPECIFICATION AND PARTS LIST

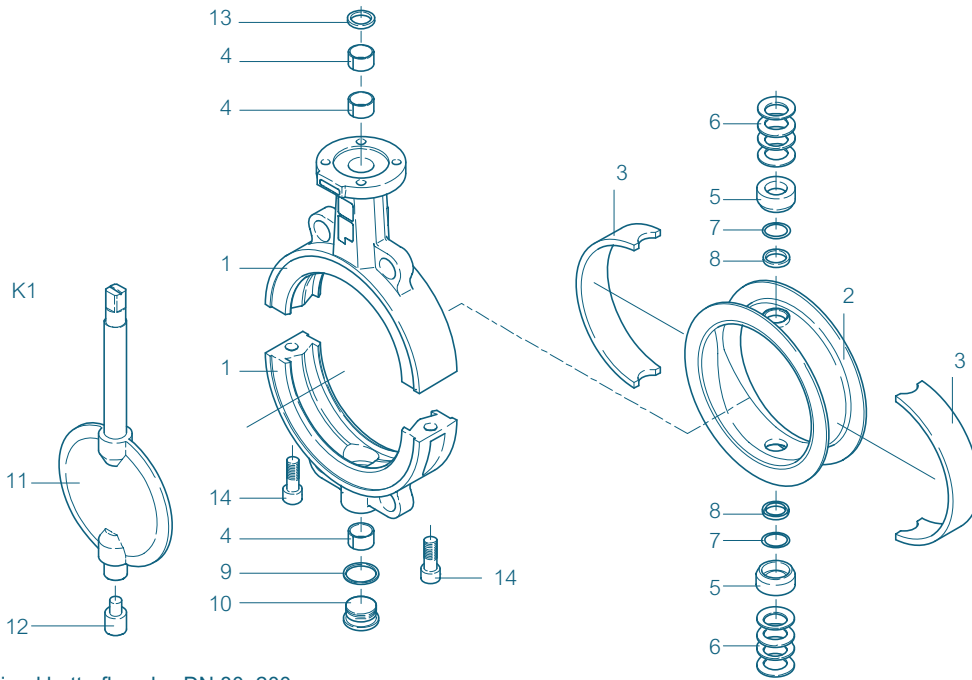

PTFE-lined butterfly valve DN 80–200

Pt.	Description	Material	Material-No.	ASTM	Pt.	Description	Material	Material-No.	ASTM
1	Body				⑧	Chevron seal			
	Nodular Cast Iron	GGG-40.3	0.7043	A395		PTFE	Polytetrafluorethylen	PTFE	PTFE
	Stainless Steel	G-X6CrNiMo18-10	1.4408	CF8M	9	Seal			
		X2CrNiMo17-12-2	1.4404	316L		Stainless Steel	X5CrNi 18-10	1.4301	304
②	Seat				10	Plug screw DIN 908			
	PTFE	Polytetrafluorethylen	PTFE	PTFE *1		Stainless Steel	G-X6CrNiMo 18-10	1.4408	CF8M
③	Elastomer insert				⑪	Disc/Shaft	one-piece		
	Silicon standard	Silicon-rubber	MVQ	VMQ		St. Steel/St. Steel	G-X2CoNiMoN26-7-4	1.4462/1.4469	F 51
	EPDM optional	Etylene propylene caoutchouk	EPDM	EPDM		St/PTFE-coated	St 52.3	1.4462/PTFE	A 572-50
	FPM optional	Flourcarbon caoutchouk					Polytetrafluorethylen	PTFE	PTFE
4	DU-bearing					Hastelloy C4		2.4610	
	Iron/PTFE coated					Titan Gr. II		3.7035	
⑤	Trust collar					St/PTFE standard		1.4462	
	Stainless Steel	X5CrNiMo 17-12-2	1.4401	316		St/PTFE		1.4462	*1
6	Bellev.spr.washer				12	Lower shaft stop			
	Stainless Steel	X12CrNi177	1.4310	301		Stainless Steel	X39CrMo17-1	1.4122	
⑦	O-Ring				13	Wiper ring			
	FPM	Flourcarbon caoutchouk	FPM	FKM		PTFE	Polytetrafluorethylen	PTFE	PTFE
	Silicon				14	Screw			
	FPM/					Stainless Steel	A4-70	1.4401	B8M
	PTFE-coated							1.4571	
						Other materials upon request.			

○ Recommended spare parts

⊙ Recommended for coated discs

*1) Optional: electrically conductive

Subject to change without notice.

PTFE-LINED BUTTERFLY VALVE T 211-A

TORQUE

- The torque values specified (MD) are based on dry media and are measured with air at a temperature of 20 °C.
- The values specified are based on the initial breakaway torque (disc disengages from seat, torque then drops).
- Dynamic torque specification available upon request.

Regarding the dimensioning of actuators, please contact our engineers.

DN [mm]	50	65	80	100	125	150	200	250	300
Size [in]	2	2½	3	4	5	6	8	10	12
MD (Nm)	40	40	70	95	130	170	230	350	480

PRESSURE/TEMPERATURE DIAGRAM

for valves with silicone elastomer inserts

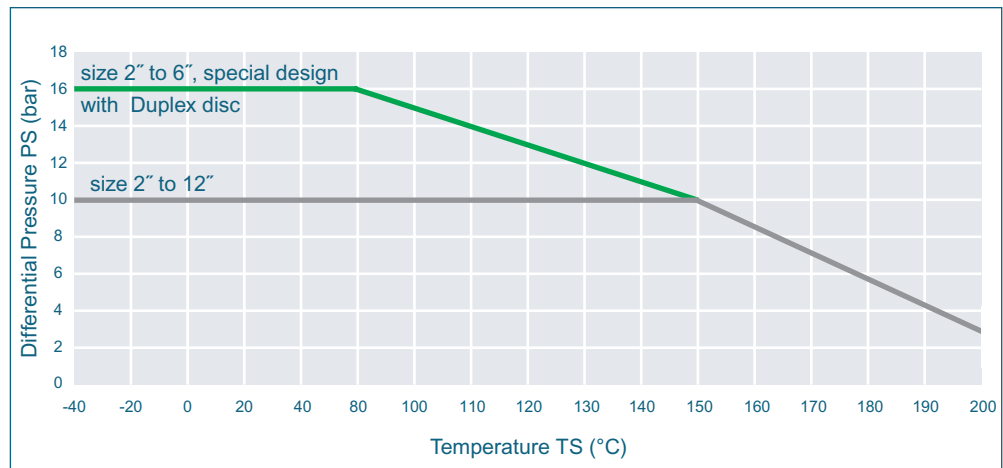

Vacuum service to 1 mbar, from -10 °C up to 160 °C

K_V-VALUES

- The K_V-value (m³ per hour) is the flow of water at a temperature of 5 °C to 30 °C (41 °F to 86 °F) at Δp of 1 bar.
- The K_V-values specified are based on tests carried out by the Delfter Hydraulics Laboratories, the Netherlands.
- Permissible velocity of flow V_{max} 4,5 m/s for liquids and V_{max} 70 m/s for gases.
- The throttle function is linear at an angle 30° to 70°.

- Avoid cavitation!

For further values, please contact our engineers.

DN [mm]	Size [in]	Opening angle α°							
		20°	30°	40°	50°	60°	70°	80°	90°
1) K _V -values metal disc									
50	2	1	8	24	50	70	100	140	210
65	2½	1	8	24	50	70	100	140	210
80	3	1,2	15	44	95	124	180	300	520
100	4	8	25	60	170	210	280	540	980
125	5	15	52	125	250	350	520	840	1400
150	6	35	95	190	350	460	850	1300	2300
200	8	69	253	457	729	1110	1783	2570	3020
250	10	120	380	690	1200	1680	2650	4500	6600
300	12	165	504	937	1512	2275	3795	6810	12800
2) K _V -values PTFE-disc									
50	2	1,5	12	28	52	70	96	110	150
65	2½	1,5	12	28	52	70	96	110	150
80	3	2,5	20	48	88	118	160	200	250
100	4	12	32	68	170	210	260	500	780
125	5	18	60	135	260	380	480	790	1250
150	6	45	105	205	370	490	720	1250	2200
200	8	88	297	520	695	1130	1700	2500	2700
250	10	148	430	695	1250	1800	2520	4350	5400
300	12	263	557	960	1560	2450	4300	6700	9400